

SBC 4010

High Performance Low Cost
Single Board Computer



Features:

- High Speed Multitasking Industry Computer **TINY-Tiger**
- SRAM / FLASH memory configurations available:
 - 128k 512k
 - 512k 512k
 - 512k 2M
- Optional battery backup: NiCd battery or GoldCap or Lithium battery (Jumper !)
- Power supply input 9...24V_{DC}, polarity protection
- typical power consumption: 1.1W with 9V supply
2.9W with 24V supply
- 1 x RS232
- 1 x RS485
- In-field programmable
- LCD connector for 1:1 flat cable to text display
- Inputs for a 4 x 4 keymatrix P60...67
- 4 analog channels: 0...10V, 0-20 mA (poti calibration)
- Analog Vref = 4V_{DC}
- 2 digital inputs (5...24V)
- 4 outputs 24V / 1A driving capability
- Board size: approx. 80 x 80 x 1.6 mm, 4 assembly holes 4.2 mm
- 2 x 90μ Cu, 10/10 mil datawire, power+GND 80 mil
- High quality screw terminals (I/O): 5.08 mm, 250V_{AC}
 - 1x DB9 for serial RS232)
 - Screw terminal for RS485

SBC 4010

High Performance Low Cost
Single Board Computer

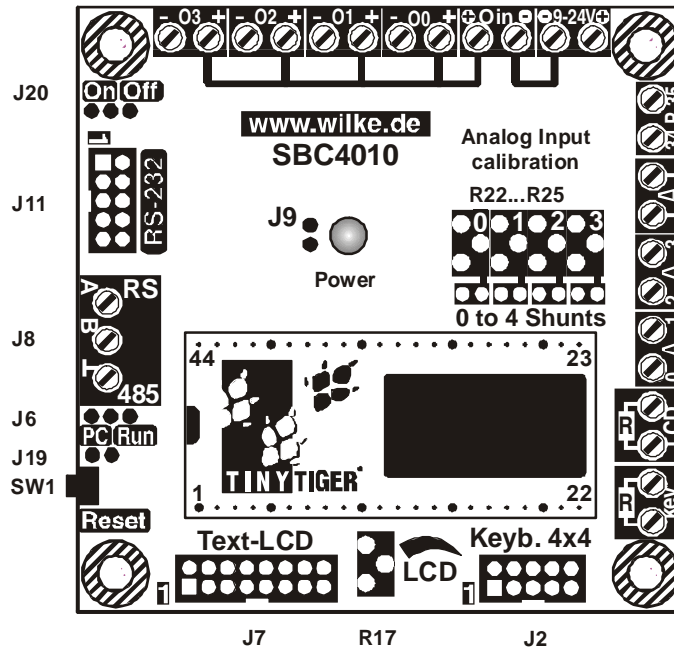

Data sheet

Overview of I/O channels, connectors:

Power	LED indicates power supply	R22..R25	Calibration 0V..10V
J9	alternative power LED	R-Key	connect ext. resistor for keyboard backlite
J6	PC mode jumper switch Setting of RUN/PC mode	R-LCD	connect ext. resistor for LCD backlite
SW1	Reset button	A0..A3	analog inputs
J19	alternative Reset input	A-GND	analog ground
J20	RS232 interface	P34..P35	24V dig. inputs
J20	RS232 power-on	9-24V	9V..24V supply voltage
J8	RS485 interface	Oin	OpenCollectorec supply input 24V max.
J7	Text-LCD	O0..O3	24V/1A open-collector output
R17	LCD-Contrast		
J2	4x4 Keyboard matrix		

SBC 4010

High Performance Low Cost Single Board Computer

Power supply

A 9V...24V DC / 120mA power supply delivers the operating voltage.

All other supply voltages are created onboard: +5V

The Power-LED indicates whether power supply is connected to SBC4010.

A second LED can be connected to **J9**.

LED specification: 2V/3mA

Battery Backup Option

A 3,6V/140mAH battery/akku can be mounted onboard to backup RAM and RealTimeClock data.

Serial Interface:

The SBC offers two serial interfaces:

- J11:** The interface Ser1 of the Tiger is lead to the DB9 connector through a V24 interface driver chip as RS232 without handshake.
J11 is used as programming interface for the Tiger module in PC mode. Set **J6** for PC-Mode.
- J20:** En-/disables RS232 to save power when not used
- J8:** The interface Ser0 of the Tiger is lead out as RS485 signal and can easily be tapped on the industrial plug.

Connection diagram serial connector:

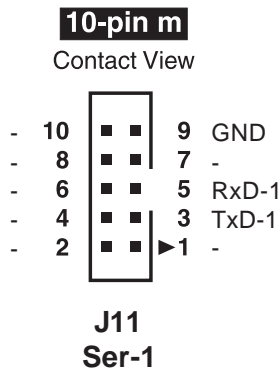

High Performance Low Cost Single Board Computer

Connection diagram Text LCD connector:

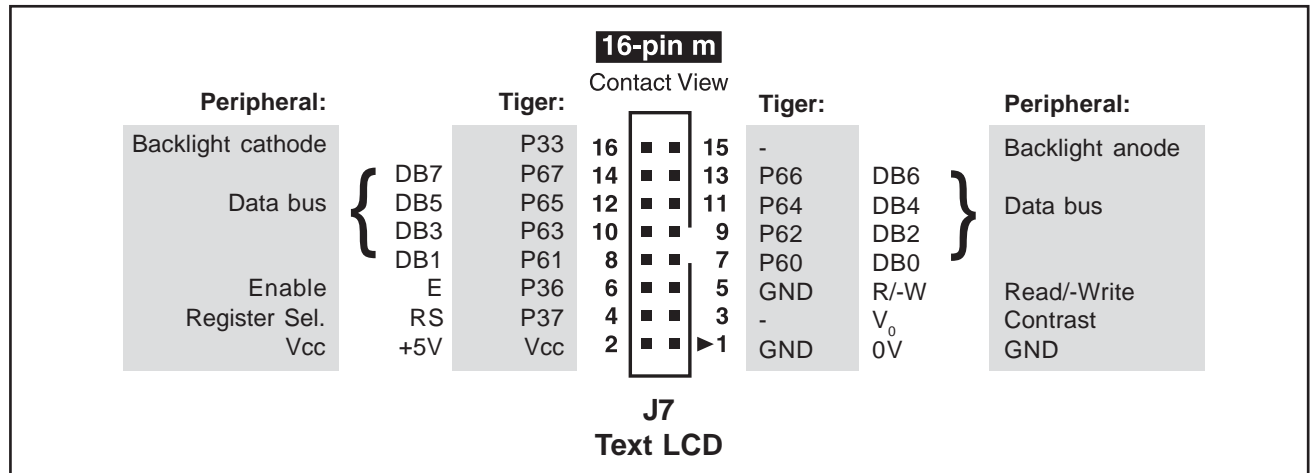

The connector J7 connects an alphanumeric LCD with HD44870 controller. The transferred functions of this connector contain:

- Power supply of LCD
- Data transfer to LCD
- LCD lighting
- LCD contrast setting

Text-LCD type: 4 x 20, 2 x 20, 2 x 16 ... and many more with controller HD44870 (and compatible).

LCD light: Is activated by setting bit LED-LCD **P33**.
Use ext. resistor for backlight supply.

$$R = \frac{24V - \text{backlight voltage}}{\text{backlight current}}$$

LCD contrast: Contrast adjustment with on-board potentiometer **R17**.

The LCD is usually controlled by device driver LCD1.TDD, which offers a large number of options and functions for text and quasi-graphic outputs.

Further and detailed description are given in Tiger-BASIC™ manual "Device Driver".

Connections:

Data-Bus:	Data I/O	DB0...DB7	P60...P67
CTRL-Bus:	Register Select	RS	P36
	Chip Enable	E	P37

SBC 4010

High Performance Low Cost Single Board Computer

Connection diagram 4x4 keyboard connector:

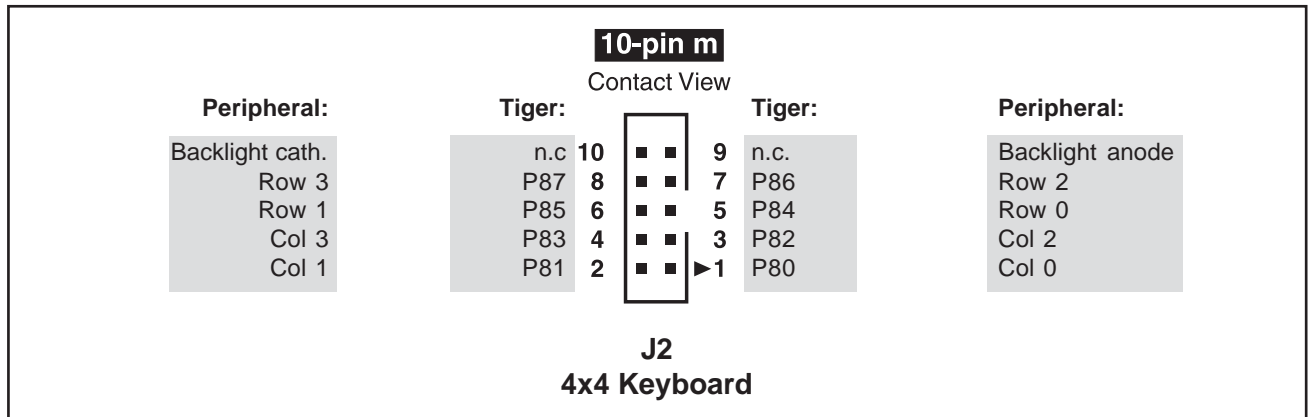

The connector J2 may be used to connect a 4x4 Keyboardmatrix or as 8 additional 5V dig. I/O:

Backlight: Is activated by setting bit
LED-LCD **P33**.
(Bit is shared with LED-LCD)
Use ext. resistor for backlight supply.
$$R = \frac{24V - \text{backlight voltage}}{\text{backlight current}}$$

All pins of J2 are protected with varistors to GND.

See sample program for 4x4 keyboard (supplied on disk).

High Performance Low Cost Single Board Computer

This program demonstrates how to read a 4 x4 keyboard matrix from a Tiger I/O port (here: port 8) without any additional components. Use P80..83 for input and P84...P87 for output.

```

-----
' Name: 4x4_MATRIX.TIG, Tiger-BASIC source code
-----

USER_VAR_STRICT

STRING KEYBUF$(64)                                'keyboard buffer (global)

TASK MAIN

BYTE X
STRING USER$(100)

INSTALL_DEVICE #1, "LCD1.TDD"                    'install LCD (4 x 20)

DIR_PORT 8, 255                                  'all pins as input
OUT 8, 0FFH, 0FFH                                'set input pins of port 8 to "pull-up"

KEYBUF$ = ""                                     'clear keyboard buffer
RUN_TASK SCAN_KEY                               'Start task to read keyboard

USER$ = ""                                       'reset user string
PRINT #1, "<1>";                                  'clear LCD screen
FOR X = 0 TO 0 STEP 0                            'endless loop
  WHILE LEN(KEYBUF$) <> 0                          's.th. in keyboard buffer?
    USER$ = LEFT$(KEYBUF$, 1)                    'read "oldest" character
    PRINT #1, USER$;                              'output it on LCD
    KEYBUF$ = RIGHT$(KEYBUF$, LEN(KEYBUF$)-1)    'delete it from buffer
  ENDWHILE
NEXT

END

-----
' this task continuously checks the port 8 for pressed keys
-----
TASK SCAN_KEY

BYTE EVER, X, KEY_NO, OLD_KEY_NO
BYTE BITVAL, INVAL, OUTVAL
STRING KEYS$(16)

KEYS$ = "ABCDEFGHIJKLMNOP"                       'the 16 keys of the keyboard,
                                                'starting with key no. 0
OLD_KEY_NO = 255                                 'set compare to "no key"
WAIT_NEXT 30                                    'initialize 30 ms wait

FOR EVER = 0 TO 0 STEP 0                         'endless loop
  WAIT_NEXT                                     'release task time

  FOR X = 4 TO 7                                 'bits for keyboard columns
    BITVAL = EXP(2, X)                           'Create value for bit x (16, 32, 64 or 128)
    OUTVAL = 255 - BITVAL                         'Create mask for DIR_PORT (239, 223, 191, 127)
    DIR_PORT 8, OUTVAL                           'Set new pin directions

    OUT 8, 255, 255 - BITVAL                     'Set output pin "low" = 0, all others "high" = 1
    IN 8, INVAL                                  'read port 8
    INVAL = INVAL BITAND 15                       'use only lower 4 bits
    SWITCH INVAL
      CASE 15: KEY_NO = 255                       'no key in column pressed
      CASE 14: KEY_NO = ((X-4)*4)                'calculate key no.
      X = X - 1                                  'same column again
      CASE 13: KEY_NO = ((X-4)*4) + 1            'calculate key no.
      X = X - 1                                  'same column again
      CASE 11: KEY_NO = ((X-4)*4) + 2            'calculate key no.
      X = X - 1                                  'same column again
      CASE 7: KEY_NO = ((X-4)*4) + 3             'calculate key no.
      X = X - 1                                  'same column again
      DEFAULT: X = X - 1                          'same column again
    ENDSWITCH

    IF KEY_NO <> OLD_KEY_NO THEN                  'if new key(value) detected
      OLD_KEY_NO = KEY_NO                        'save it for comparing
      IF KEY_NO <> 255 THEN                       'if not "no key"
        KEYBUF$ = KEYBUF$ + MID$(KEYS$, KEY_NO, 1) 'add key to keyboard buffer
      ENDIF
    ENDIF

  NEXT                                           'next column
NEXT
END

```

SBC 4010



High Performance Low Cost Single Board Computer

Data sheet

Four 0V...10V analog Inputs:

Analog 0...3: Basic Tiger analog inputs with impedance converter, analog values 0...5V possible. Likewise usable as 20mA current -input if a 8x250Ω SIL array is placed .

Calibration: Each input can be calibrated 0V.. 10V standalone.

To calibrate to 5V apply 2.5V to the input and read analog port. With R22...25 set inputvalue to 512 digits.

To calibrate to 10V apply 5V to the input and proceed as above.

Reference: Tiger Vref is 4V from 3.9V zener diode.

Analog GND: All analog inputs have common AGND. AGND is normally connected to Tiger-GND. To separate remove **R35**.

Two digital Inputs (5V-24V):

Dig. Inputs: The 2 digital inputs are connected to Tiger pins P34 & P35.

Onboard are 3.9V zener diodes to prevent damage on Tiger inputs when voltages > 5V are connected to board input.

Those digital inputs get read as usual Tiger-input.

To use this P34 P35 as counter inputs implement the new device driver "CNT1_345.TDD" and "CNT1_354.TDD" supplied on disk.

Four Open Collector Outputs:

OC 0...3: The Open Collector outputs are connected to Tiger pins P70...P73.

OC3 & OC4 are connected to the PWM Outputs of Tiger and can get used like this.

Specification: 24V / 1 Amp driving capability MOSFET technology.